

AUTEL®

Web: www.autel.com
www.maxitpms.com

PROGRAMMABLE UNIVERSAL COMMERCIAL VEHICLE TPMS SENSOR MX-Sensor CVS-A01

With Metal Band for Rim Size of: 14"-24.5"

PATENT

This product is protected by patents in the U.S. and elsewhere. For more information, please visit <https://autel.us/virtual-patents/>.

⚠ CAUTION

- Autel MX-Sensor CVS-A01 arrives blank and must be programmed with an Autel CV TPMS tool. We recommend you program the CV sensor prior to installation.
- Do not race a vehicle on which the MX-Sensor CVS-A01 with a metal band is installed, and always keep the drive speed under 240 km/h (150 mph).

SAFETY INSTRUCTIONS

- Before installing the CV sensor, read the installation and safety instructions carefully. For reasons of safety and for optimal operation, we recommend that any maintenance and repair work be carried out by trained experts only, in accordance with the guidelines of the vehicle manufacturer. The metal bands are meant to provide safety and are intended for professional installation only. Failure to heed these warnings may result in the failure of the CV TPMS sensor. AUTEL does not assume any liability in case of faulty or incorrect installation of the product.

⚠ CAUTION

- The CV TPMS sensor assemblies are replacement or maintenance parts for vehicles with factory-installed TPMS.
- Make sure to program the sensors using AUTEL TPMS programming tools for the specific vehicle make, model, and year before installation.
- Do not install non-programmed CV TPMS sensors in damaged wheels.
- In order to guarantee optimal functionality, the sensors can only be installed with original bands and accessories provided by AUTEL.
- Upon completing the installation, test the vehicle's TPMS following the procedures described in the original manufacturer's user guide to confirm proper installation.

✓ WARRANTY

AUTEL guarantees that the sensor is free from material and manufacturing defects for twenty-four (24) months or for 62,100 miles (100,000 km), whichever comes first. AUTEL will, at its discretion, replace any merchandise during the warranty period. The warranty shall be void if any of the following occurs:

1. Improper installation of products
2. Improper usage
3. Induction of defect by other products
4. Mishandling of products
5. Incorrect application
6. Damage due to collision or tire failure
7. Damage due to racing or competition
8. Exceeding specific limits of the product

CUSTOMER & TECH SUPPORT

☎ 1-855-288-3587 (US)

+49(0)89 540299608 (EU)

+86 (0755) 8614-7779 (CN)

✉ sales@autel.com | supportpms@auteltech.com

🌐 www.autel.com | www.maxitpms.com

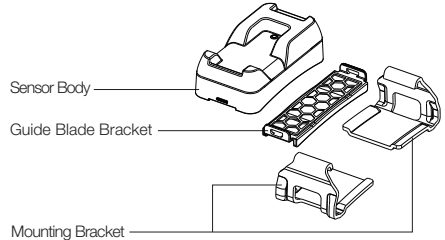

Technical Specifications

Weight (sensor body only)	26.3 g
Dimensions	59.5 x 29.4 x 22.8 mm
Max. pressure range (relative)	1400 kPa

⚠ CAUTION:

- When mounting the sensor onto the wheel rim, make sure the arrow on the sensor surface points to the valve.
- If the initial purchase included a fabric band and you wish to switch to a metal band, please adhere to the following installation steps.
- Each time a tire is serviced or dismantled, or if the sensor is removed or replaced, it is suggested to replace the band, mounting brackets, and guide blade bracket.
- Both fabric bands and metal bands can be purchased separately.

INSTALLATION GUIDE

▲ IMPORTANT: Before operating or maintaining this product, please read these instructions carefully and pay extra attention to the safety warnings and precautions. Use this unit correctly and with care. Failure to do so may cause damage and/or personal injury and will void the warranty.

1 Loosen the tire

Remove the valve cap and core and deflate the tire. Unseat the tire bead opposite the sensor and valve.

2 Dismount the tire

▲ CAUTION: Before dismounting the tire, make sure that the tire and rim are properly lubricated. When using a tire machine, refer to the instructions from both the manufacturer and Autel to dismount the tire from the rim.

2.1 When using a vertical tire machine to dismount the commercial tire

Step 1: Place the lubricated tire onto a vertical tire machine (Fig.1) with the sensor at the 11 o'clock position and the mounting hook at the 8 o'clock position (Fig.2). Rotate the rim counterclockwise so that the sensor is at the 9 o'clock position (Fig.3). Make sure that the mounting hook does not contact the sensor.

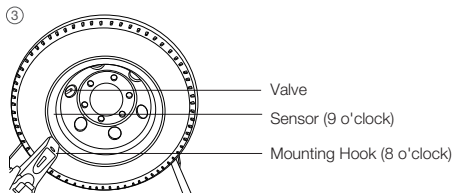
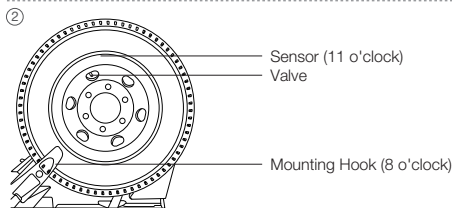
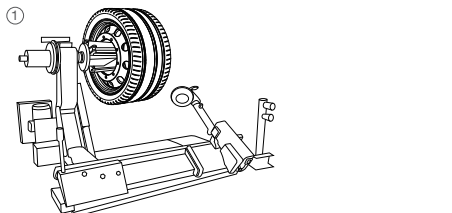

Step 2: Adjust the mounting hook to lift the tire bead over the rim flange, and then advance the rim counterclockwise to remove the front tire bead.

Step 3: Adjust the bead loosener disk to position it behind the tire bead (Fig.4). Rotate the rim counterclockwise while slowly advancing the bead loosener disk to dismount the rear tire bead.

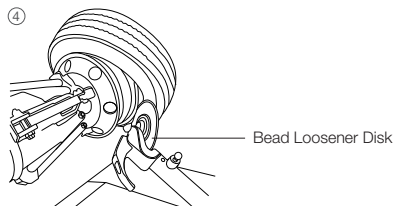

2.2 When using a horizontal tire machine to dismount the light commercial tire

Step 1: Place the lubricated tire onto a horizontal tire machine (Fig.5) with the mounting head at the 12 o'clock position and the sensor at the 11 o'clock position (Fig.6).

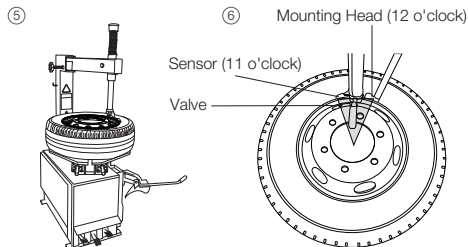

▲ CAUTION: This starting position must be observed during the whole dismounting process.

Step 2: Lift the tire bead over the rim flange with the bead lifting bar and advance the rim clockwise to dismount the top tire bead.

Step 3: Repeat Steps 1 and 2 to dismount the bottom tire bead.

2.3 When using a tire iron to dismount the commercial tire

▲ CAUTION: Not recommended. Only trained professionals should perform the method to prevent injury, tire and rim damage, and low efficiency.

Step 1: Use a tire iron to lift the top tire bead near the sensor over the rim flange. Gradually work around the sensor to release the tire bead, ensuring the tire iron does not contact the sensor.

Step 2: Repeat Step 1 to remove the bottom tire bead.

3 Dismount the sensor and band

▲ CAUTION: Take protective measures and handle the metal band carefully to prevent injury.

If the old sensor is an OE sensor, follow the vehicle manufacturer's guidelines.

If it is an Autel MX-sensor with a metal band, use a TX30 torque wrench to loosen the screw on the metal band. Then, remove the metal band and slide the sensor off.

4 Mount the sensor and band

Step 1: Wear gloves and carefully cut the packaging strap. Hold onto the screw end of the metal band to prevent injury from sharp edges and sudden release (Fig.7).

Step 2: Wrap the metal band once around the rim at the lowest point of the drop center. Mark it 1" (2.5 cm) beyond the screw and cut at the mark (Fig.8). Any excess band should be removed to prevent it from breaking off and damaging the tire, and to speed up the tightening process.

Step 3: Slide the sensor onto the band, aligning the arrow on its surface towards the valve. Make sure that both the metal band and the sensor are positioned at the lowest point of the drop center.

Step 4: Thread the band end through the screw, and adjust the position of the sensor to ensure it remains 7.8" (20 cm) away from the edge of the screw (Fig.9). Pre-tighten the screw with a TX30 torque wrench.

NOTE: If using a vertical tire machine to mount the tire, position the sensor at the 12 o'clock position to prevent it from falling.

Step 5: Hold the sensor in place and securely tighten the screw to 53 in-lbs (6 N•m) with the TX30 torque wrench (Fig.10).

⚠ CAUTION:

- The arrow on the sensor surface must point towards the valve so as to easily identify the position of the sensor during and after the tire mounting.
- The band must be flat and even, and parallel to the edge of the rim.

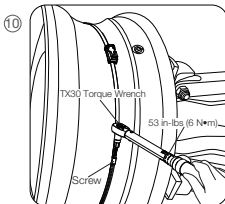
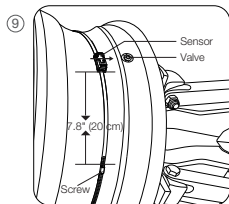
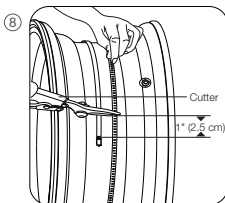
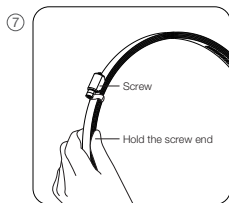

5 Mount the tire

⚠ CAUTION: When using a tire machine to mount the tire onto the rim, refer to the instructions from both the manufacturer and Autel.

5.1 When using a vertical tire machine to mount the commercial tire

Step 1: Place the rim onto a vertical tire machine with the rim flange clamp at the 12 o'clock position, the sensor at the 2 o'clock position, and the mounting hook at the 8 o'clock position (Fig.11).

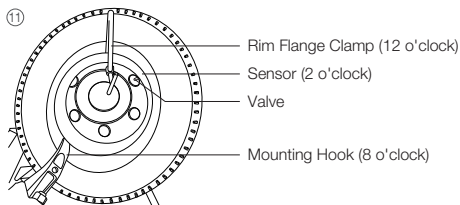

Step 2: Advance the rim clockwise to slide both tire beads over the rim flange simultaneously. Make sure that the tire is mounted onto the rim without contacting the sensor.

5.2 When using a horizontal tire machine to mount the light commercial tire

Step 1: Place the rim onto the tire machine, with the sensor at the 6 o'clock position and the mounting head at the 12 o'clock position (Fig.12).

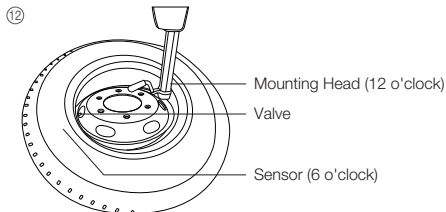

Step 2: Advance the bottom bead clockwise and slide it over the rim flange to mount it onto the rim. Make sure that the bead does not contact the sensor.

Step 3: Repeat Steps 1 and 2 to mount the top tire bead onto the rim.

5.3 When using a tire iron to mount the commercial tire

⚠ CAUTION: Not recommended. Only trained professionals should perform the method to prevent injury, tire and rim damage, and low efficiency.

Step 1: Opposite the sensor, use a tire iron to push the tire bead under the rim flange. Then work over the flange towards the sensor until the bottom bead slides over the rim flange at the sensor without contacting it.

Step 2: Repeat Step 1 to mount the top tire bead.

Notice: Dual wheels must be installed on the vehicle with the valves directly opposite each other or as close to 180° apart as possible to accurately program or activate the inside and outside sensors and prevent interference between the two sensors (Fig.13).

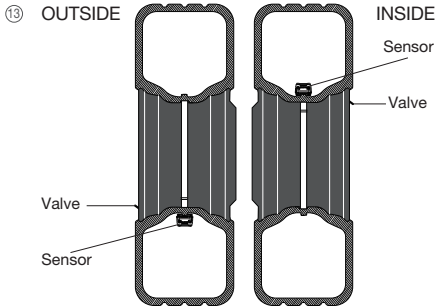

SHARP ELEMENT WARNING



ISO 7010-W022

BATTERY WARNING

⚠ WARNING	
<ul style="list-style-type: none">• INGESTION HAZARD: This product contains a button cell or coin battery.• DEATH or serious injury can occur if ingested.• A swallowed button cell or coin battery can cause Internal Chemical Burns in as little as 2 hours.• KEEP new and used batteries OUT OF REACH OF CHILDREN.• Seek immediate medical attention if a battery is suspected to be swallowed or inserted inside any part of the body.	

- 1) Remove and immediately recycle or dispose of used batteries according to local regulations and keep away from children. Do NOT dispose of batteries in household trash or incinerate.
- 2) Even used batteries may cause severe injury or death.
- 3) Call a local poison control center for treatment information.
- 4) The compatible battery type (CR2450).
- 5) The nominal battery voltage: 3V.
- 6) Non-rechargeable batteries are not to be recharged.
- 7) Do not force discharge, recharge, disassemble, heat above 100 °C or incinerate. Doing so may result in injury due to venting, leakage or explosion resulting in chemical burns.



Web: www.autel.com
www.maxitpms.com



AUTEL guarantees that the sensor is free from material and manufacturing defects for twenty-four (24) months or for 62,100 miles (100,000 km), whichever comes first. AUTEL will, at its discretion, replace any merchandise during the warranty period. The warranty shall be void if any of the following occurs:

1. Improper installation of products
2. Improper usage
3. Induction of defect by other products
4. Mishandling of products
5. Incorrect application
6. Damage due to collision or tire failure
7. Damage due to racing or competition
8. Exceeding specific limits of the product

PROGRAMMABLE UNIVERSAL COMMERCIAL VEHICLE TPMS SENSOR

MX-Sensor CVS-A01

With Fabric Band for Rim Size of: ■ 14"-17.5"
 ■ 17.5"-24.5"

PATENT

This product is protected by patents in the U.S. and elsewhere. For more information, please visit <https://autel.us/virtual-patents/>.

⚠ CAUTION

- Autel MX-Sensor CVS-A01 arrives blank and must be programmed with an Autel CV TPMS tool. We recommend you program the CV sensor prior to installation.
- Do not race a vehicle on which the MX-Sensor CVS-A01 with a fabric band is installed, and always keep the drive speed under 130 km/h (80 mph).

SAFETY INSTRUCTIONS

- Before installing the CV sensor, read the installation and safety instructions carefully. For reasons of safety and for optimal operation, we recommend that any maintenance and repair work be carried out by trained experts only, in accordance with the guidelines of the vehicle manufacturer. The fabric bands are meant to provide safety and are intended for professional installation only. Failure to heed these warnings may result in the failure of the CV TPMS sensor. AUTEL does not assume any liability in case of faulty or incorrect installation of the product.

⚠ CAUTION

- The CV TPMS sensor assemblies are replacement or maintenance parts for vehicles with factory-installed TPMS.
- Make sure to program the sensors using AUTEL TPMS programming tools for the specific vehicle make, model, and year before installation.
- Do not install programmed CV TPMS sensors in damaged wheels.
- In order to guarantee optimal functionality, the sensors can only be installed with original bands and accessories provided by AUTEL.
- Upon completing the installation, test the vehicle's TPMS following the procedures described in the original manufacturer's user guide to confirm proper installation.

CUSTOMER & TECH SUPPORT

- ☎ 1-855-288-3587 (US)
 +49(0)89 540299608 (EU)
 +86 (0755) 8614-7779 (CN)
- ✉ sales@autel.com | supportpms@auteltech.com
- 🌐 www.autel.com | www.maxitpms.com



Technical Specifications

Weight (sensor body only)	26.3 g
Dimensions	54.0 x 29.4 x 18.1 mm
Max. pressure range (relative)	1400 kPa

⚠ CAUTION:

- When mounting the sensor onto the wheel rim, make sure the arrows on the sensor and band pocket point to the valve.
- If the initial purchase included a metal band and you wish to switch to a fabric band, please adhere to the following installation steps (take the fabric band for rim size of 17.5"-24.5" as the example).
- Each time a tire is serviced or dismounted, or if the sensor is removed or replaced, it is suggested to replace the band.
- Both fabric bands and metal bands can be purchased separately.

INSTALLATION GUIDE

- ⚠ **IMPORTANT:** Before operating or maintaining this product, please read these instructions carefully and pay extra attention to the safety warnings and precautions. Use this unit correctly and with care. Failure to do so may cause damage and/or personal injury and will void the warranty.

1 Loosen the tire

Remove the valve cap and core and deflate the tire. Unseat the tire bead opposite the sensor and valve.

2 Dismount the tire

▲ CAUTION: Before dismounting the tire, make sure that the tire and rim are properly lubricated. When using a tire machine, refer to the instructions from both the manufacturer and Autel to dismount the tire from the rim.

2.1 When using a vertical tire machine to dismount the commercial tire

Step 1: Place the lubricated tire onto a vertical tire machine (Fig.1) with the sensor at the 11 o'clock position and the mounting hook at the 8 o'clock position (Fig.2). Rotate the rim counterclockwise so that the sensor is at the 9 o'clock position (Fig.3). Make sure that the mounting hook does not contact the sensor.

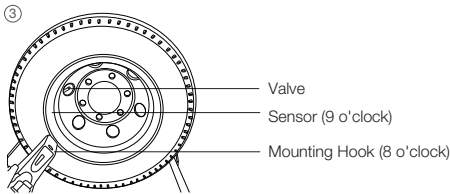
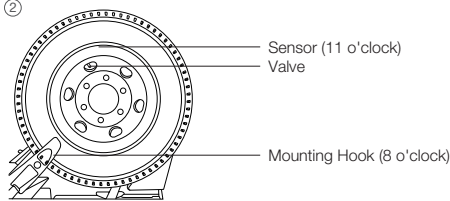
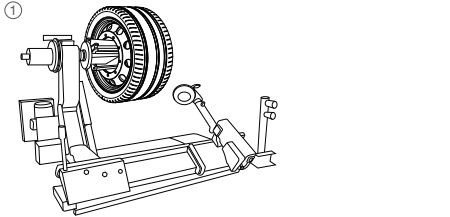

Step 2: Adjust the mounting hook to lift the tire bead over the rim flange, and then advance the rim counterclockwise to remove the front tire bead.

Step 3: Adjust the bead loosener disk to position it behind the tire bead (Fig.4). Rotate the rim counterclockwise while slowly advancing the bead loosener disk to dismount the rear tire bead.

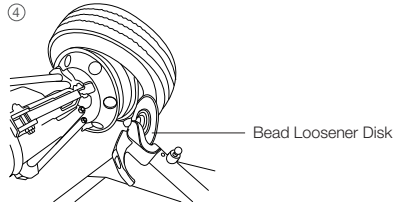

2.2 When using a horizontal tire machine to dismount the light commercial tire

Step 1: Place the lubricated tire onto a horizontal tire machine (Fig.5) with the mounting head at the 12 o'clock position and the sensor at the 11 o'clock position (Fig.6).

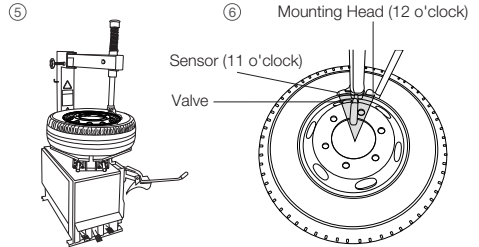

▲ CAUTION: This starting position must be observed during the whole dismounting process.

Step 2: Lift the tire bead over the rim flange with the bead lifting bar and advance the rim clockwise to dismount the top tire bead.

Step 3: Repeat Steps 1 and 2 to dismount the bottom tire bead.

2.3 When using a tire iron to dismount the commercial tire

▲ CAUTION: Not recommended. Only trained professionals should perform the method to prevent injury, tire and rim damage, and low efficiency.

Step 1: Use a tire iron to lift the top tire bead near the sensor over the rim flange. Gradually work around the sensor to release the tire bead, ensuring the tire iron does not contact the sensor.

Step 2: Repeat Step 1 to remove the bottom tire bead.

3 Dismount the sensor and band

If the old sensor is an OE sensor, follow the vehicle manufacturer's guidelines.

If it is an Autel MX-sensor with a fabric band, unthread the Velcro, remove the band, and extract the sensor from the band pocket.

4 Mount the sensor and band

Step 1: Insert the sensor into the band pocket with their top surfaces positioned on the same side and the arrows aligned in direction (Fig.7).

Step 2: Wrap the fabric band once around the rim at the lowest point of the drop center with the top surface of the band pocket facing outward and the arrow towards the valve.

NOTE: If using a vertical tire machine to mount the tire, position the sensor at the 12 o'clock position to prevent it from falling.

Step 3: Thread the Velcro through the ladder buckle (Fig.8). Place the plastic loop near the end of the band to make it easier for the end to pass through after tightening.

Step 4: Hold the sensor and tighten the band with a tensile force of approximately 100 N, then secure the Velcro (Fig.9).

Step 5: Slide the plastic loop over the end of the band to secure it and prevent from flipping up due to the force (Fig.10).

⚠ CAUTION:

- The arrows on the sensor and band pocket must point towards the valve so as to easily identify the position of the sensor during and after the tire mounting.
- The band must be flat and even, and parallel to the edge of the rim.

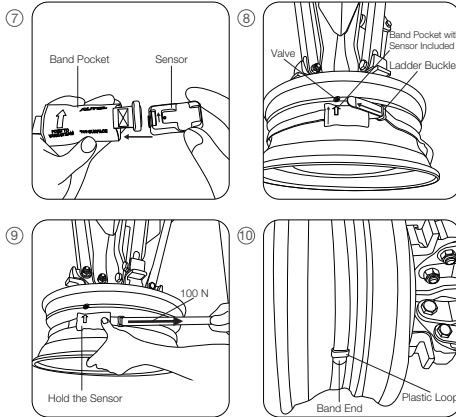

5 Mount the tire

⚠ CAUTION: When using a tire machine to mount the tire onto the rim, refer to the instructions from both the manufacturer and Autel.

5.1 When using a vertical tire machine to mount the commercial tire

Step 1: Place the rim onto a vertical tire machine with the rim flange clamp at the 12 o'clock position, the sensor at the 2 o'clock position, and the mounting hook at the 8 o'clock position (Fig.11).

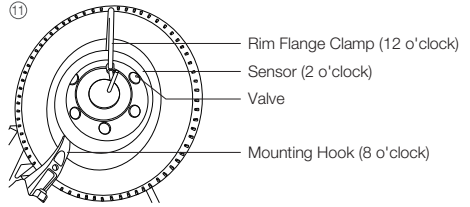

Step 2: Advance the rim clockwise to slide both tire beads over the rim flange simultaneously. Make sure that the tire is mounted onto the rim without contacting the sensor.

5.2 When using a horizontal tire machine to mount the light commercial tire

Step 1: Place the rim onto the tire machine, with the sensor at the 6 o'clock position and the mounting head at the 12 o'clock position (Fig.12).

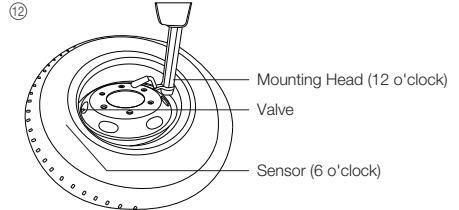

Step 2: Advance the bottom bead clockwise and slide it over the rim flange to mount it onto the rim. Make sure that the bead does not contact the sensor.

Step 3: Repeat Steps 1 and 2 to mount the top tire bead onto the rim.

5.3 When using a tire iron to mount the commercial tire

⚠ CAUTION: Not recommended. Only trained professionals should perform the method to prevent injury, tire and rim damage, and low efficiency.

Step 1: Opposite the sensor, use a tire iron to push the tire bead under the rim flange. Then work over the flange towards the sensor until the bottom bead slides over the rim flange at the sensor without contacting it.

Step 2: Repeat Step 1 to mount the top tire bead.

Notice: Dual wheels must be installed on the vehicle with the valves directly opposite each other or as close to 180° apart as possible to accurately program or activate the inside and outside sensors and prevent interference between the two sensors (Fig.13).

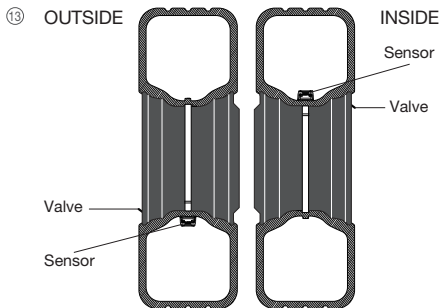

BATTERY WARNING

⚠ WARNING	
<ul style="list-style-type: none">• INGESTION HAZARD: This product contains a button cell or coin battery.• DEATH or serious injury can occur if ingested.• A swallowed button cell or coin battery can cause Internal Chemical Burns in as little as 2 hours.• KEEP new and used batteries OUT OF REACH of CHILDREN.• Seek immediate medical attention if a battery is suspected to be swallowed or inserted inside any part of the body.	

- 1) Remove and immediately recycle or dispose of used batteries according to local regulations and keep away from children. Do NOT dispose of batteries in household trash or incinerate.
- 2) Even used batteries may cause severe injury or death.
- 3) Call a local poison control center for treatment information.
- 4) The compatible battery type (CR2450).
- 5) The nominal battery voltage: 3V.
- 6) Non-rechargeable batteries are not to be recharged.
- 7) Do not force discharge, recharge, disassemble, heat above 100 °C or incinerate. Doing so may result in injury due to venting, leakage or explosion resulting in chemical burns.